

Cautions and Warnings

1. This product must be installed in accordance with the applicable installation code by a licensed electrician familiar with the construction and operation of the product and hazards involved.
2. Power must be OFF when connecting the fixture. "hot plugging" the light engine and driver will damage the LED source.
3. The light engine is low voltage and is factory wired to the driver DO NOT CONNECT LIGHT ENGINE TO MAINS AC POWER.
4. LEDs should be protected from dust and debris during installation and maintenance.
5. Polarity is important. Black must be connected to black and red connected to red.

Step B

Cut opening in ceiling to large enough to clear the connection hardware used to allow for flush mount of fixture. Refer to submittal drawing or cutsheet for location and quantity of feeds.

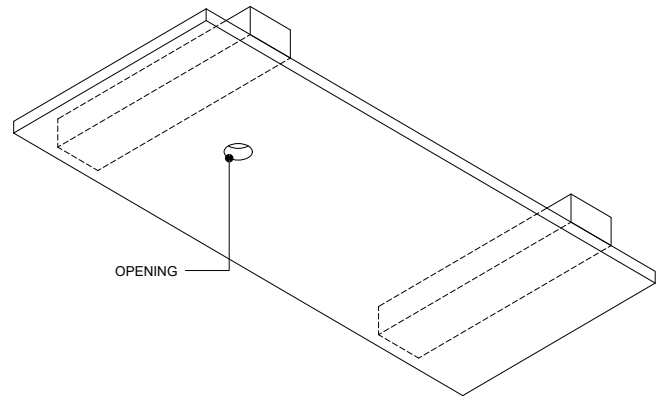

Step A

Install blocking tied to framing at mounting points behind surface fixture is being mounted to at locations as indicated in submittal drawing. Refer to submittal drawing for location and quantity of mounting holes.

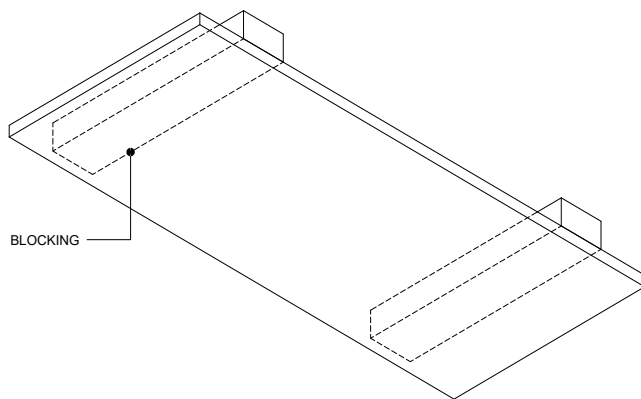

Step C

Remove LED/driver assembly from housing by pulling LED/driver until springs retaining assembly in housing are clear of housing and gain access to make electrical connection.

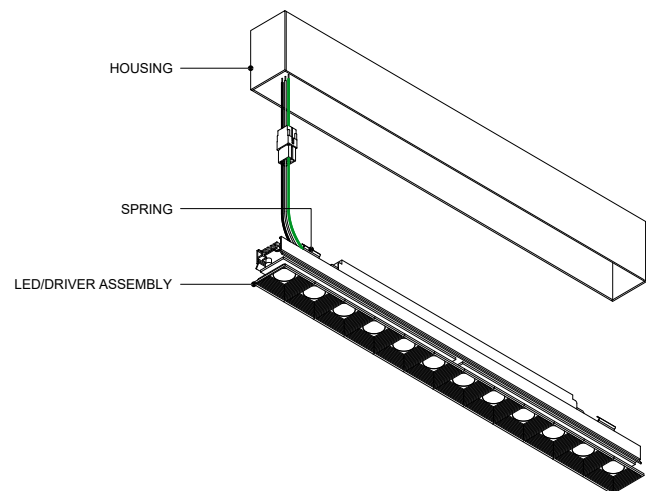

**** LED'S SHOULD BE PROTECTED FROM DUST AND DEBRIS DURING INSTALLATION AND MAINTENANCE**

[Click here to read full Care and Maintenance](#)

Step D

Prior to installing the housing on surface. Connect power to housing at feed location on top of housing, leaving 6" leads in place for connections to LED assembly and drivers.

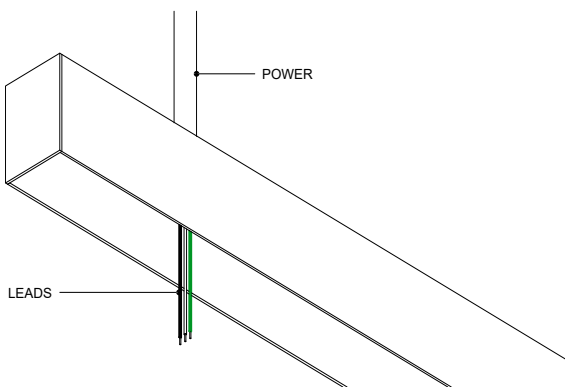

Step F

For run lengths that require multiple sections. Pin/joiners may be moved by loosening set screw with 2mm hex wrench and sliding within slot inside of the housing. Lift housing into place until flush and aligned. Guide pin/joiner into corresponding slot. Tighten set screws on pin/joiners to secure housings to one another. Mount housing to surface as shown in step E.

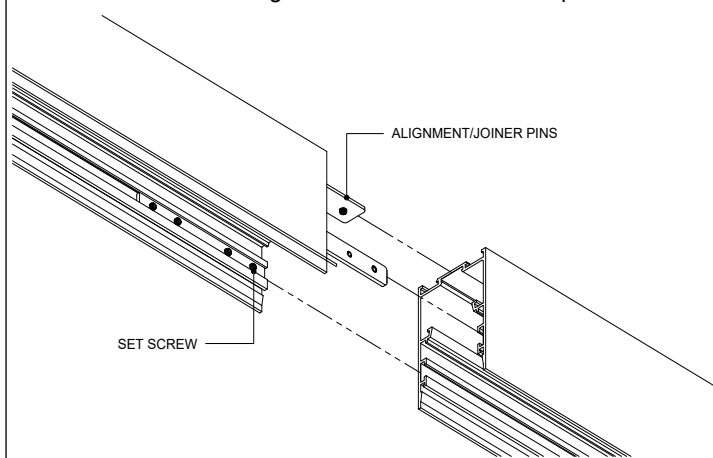

Step E

Mount housing to surface with wood screws or fasteners suitable for blocking material used (by others) through housing into blocking.

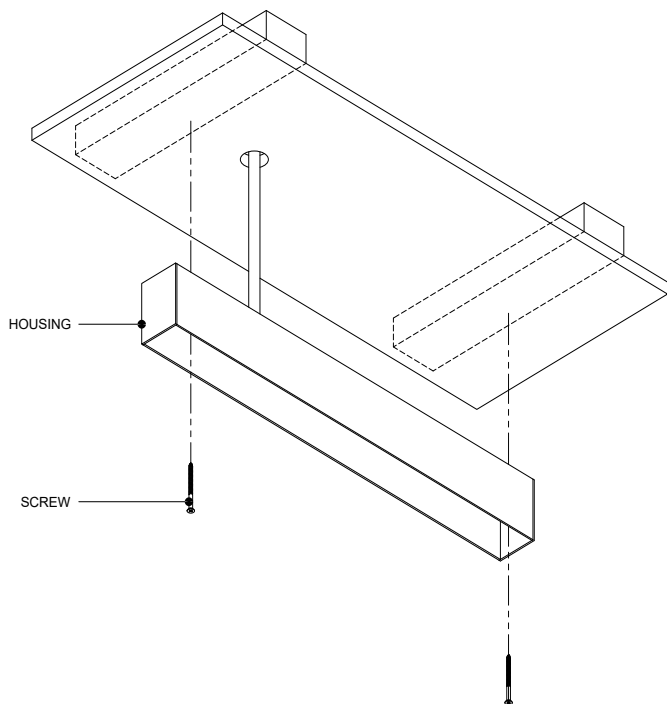

Step G

Prior to reinstalling LED/driver assembly into housing, make electrical connection between housing and LED/driver assembly, connect included safety cables then secure assembly to housing by pushing assembly into housing until springs on LED/driver assembly securely engage the housing. Turn on power to check electrical connection.

