

Installation Instructions

Slice 2" Continuous Linear Multicell Downlight (54mm)

for SL2DC-MCRC-P

Cautions and Warnings

1. This product must be installed in accordance with the applicable installation code by a licensed electrician familiar with the construction and operation of the product and hazards involved.
2. Power must be OFF when connecting the fixture. "hot plugging" the light engine and driver will damage the LED source.
3. The light engine is low voltage and is factory wired to the driver DO NOT CONNECT LIGHT ENGINE TO MAINS AC POWER.
4. Polarity is important. Black must be connected to black and red connected to red.

Step A

Refer to cutsheets for ceiling cutout dimensions based upon overall fixture length. Install blocking, tied to framing based upon ceiling cut-out dimensions. Cut rectangular ceiling cut-out and install sheetrock so that ceiling cut-out and blocking align.

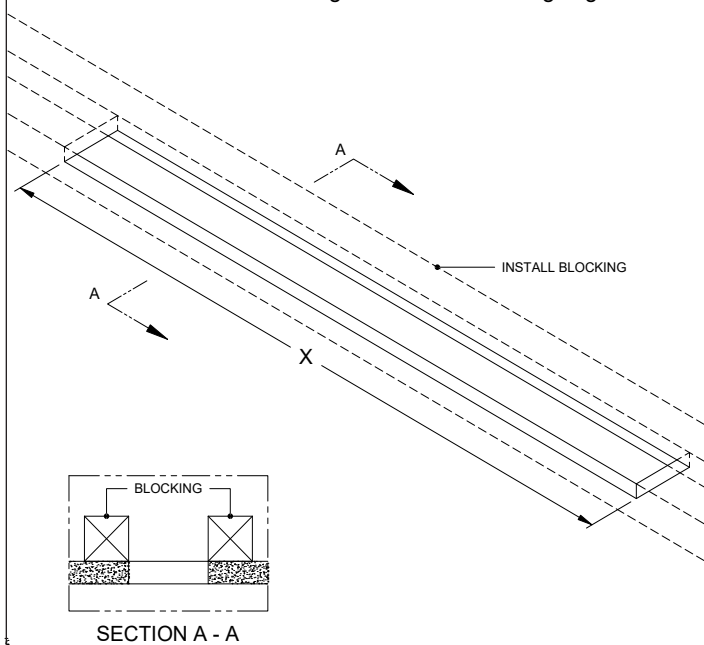

Step B

Remove LED/driver assembly from housing by pulling LED/driver until springs retaining assembly in housing are clear of housing to gain access to adjust deployable mounting bracket. Once removed LED/driver assembly should be protected from dust and debris.

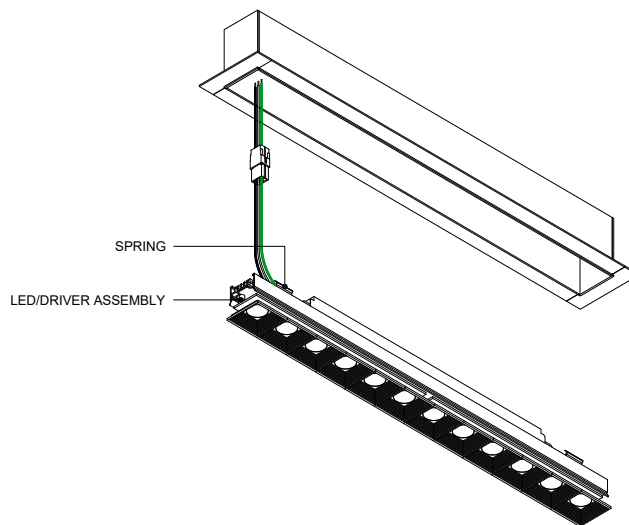

Step C

Prior to installing the housing in ceiling. Connect power to housing at feed location on top of housing, leaving 6" leads in place for connections to LED assembly and drivers.

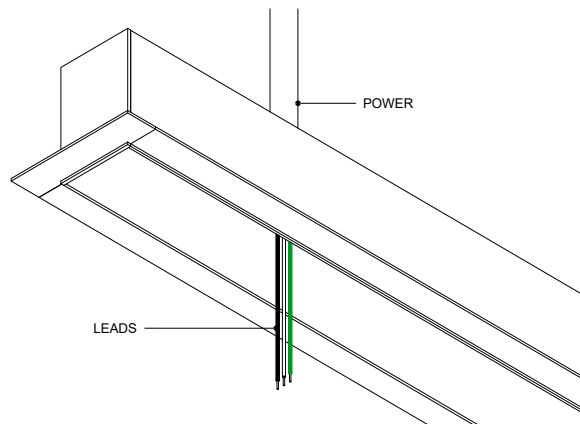

Step D

Lift housing into cut out until flange is in contact with ceiling and flush all around.

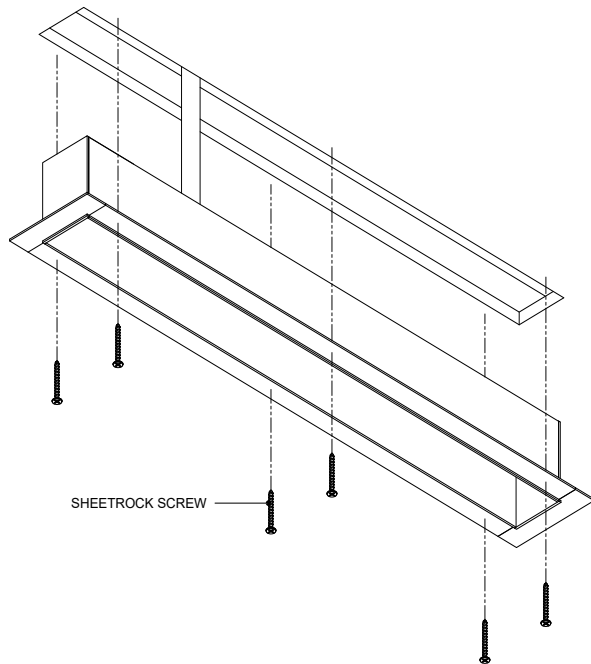

Step F

Finish ceiling, including mudding or plastering mud flange. (Take care not to get paint or joint compound within housing.)

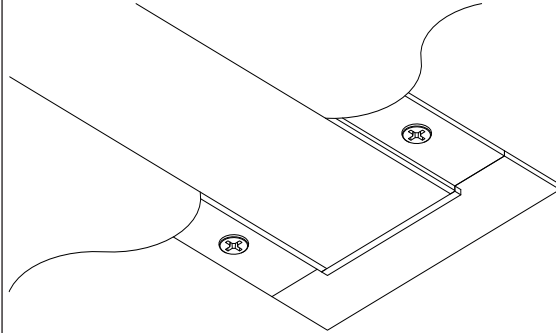

Step E

Secure housing to ceiling/blocking at 12" o.c. using appropriately sized sheetrock screws to engage blocking a minimum of 3/4".

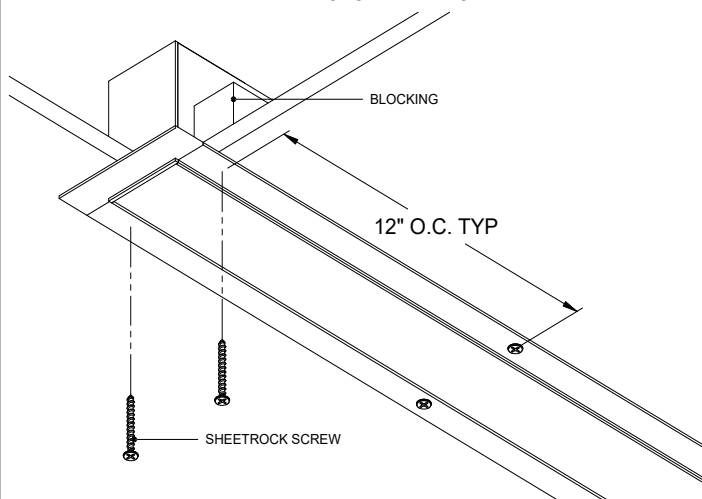

Step G

For run lengths that require multiple sections. Pin/joiners may be moved by loosening set screw with 2mm hex wrench and sliding within slot inside of the housing. Lift housing into place until flush and aligned. Guide pin/joiner into corresponding slot. Tighten set screws on pin/joiners to secure housings to one another. Install sheetrock screw through plaster flange into blocking as shown in step E.

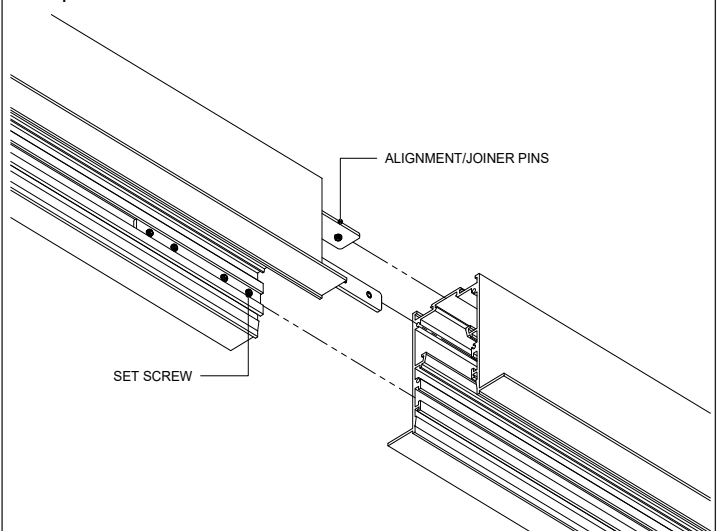

Step H

Prior to reinstalling LED/driver assembly into housing, make electrical connection between housing and LED/driver assembly, connect included safety cables then secure assembly to housing by pushing assembly into housing until springs on LED/driver assembly securely engage the housing. Turn on power to check electrical connection.

