

Cautions and Warnings

1. This product must be installed in accordance with the applicable installation code by a licensed electrician familiar with the construction and operation of the product and hazards involved.
2. Power must be OFF when connecting the fixture. "hot plugging" the light engine and driver will damage the LED source.
3. The light engine is low voltage and is factory wired to the driver DO NOT CONNECT LIGHT ENGINE TO MAINS AC POWER.
4. LEDs should be protected from dust and debris during installation and maintenance.
5. Polarity is important. Black must be connected to black and red connected to red.

Step B

Make electrical connections in junction box.

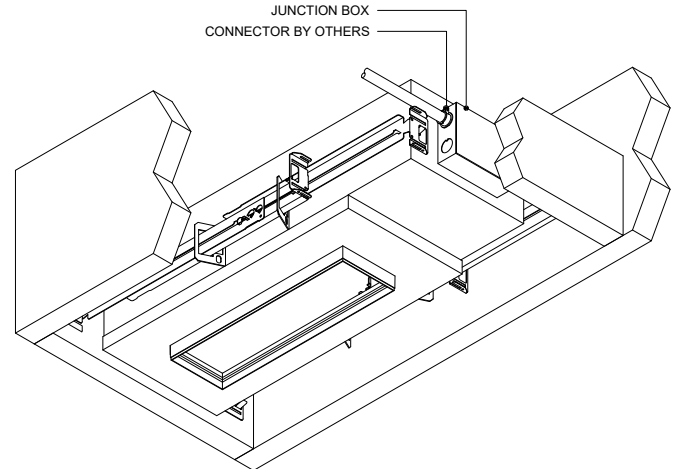

Step A

Mount housing to structure using included hanger bars. Adjust butterfly bracket position using internal wing nut to bottom of slot, so that housing is in highest position with respect to butterfly bracket. Mount housing so face of throat is 1/4" above elevation of finished ceiling. In this position housing will be able to be adjusted so that the face of throat can meet the final elevation of finished ceiling.

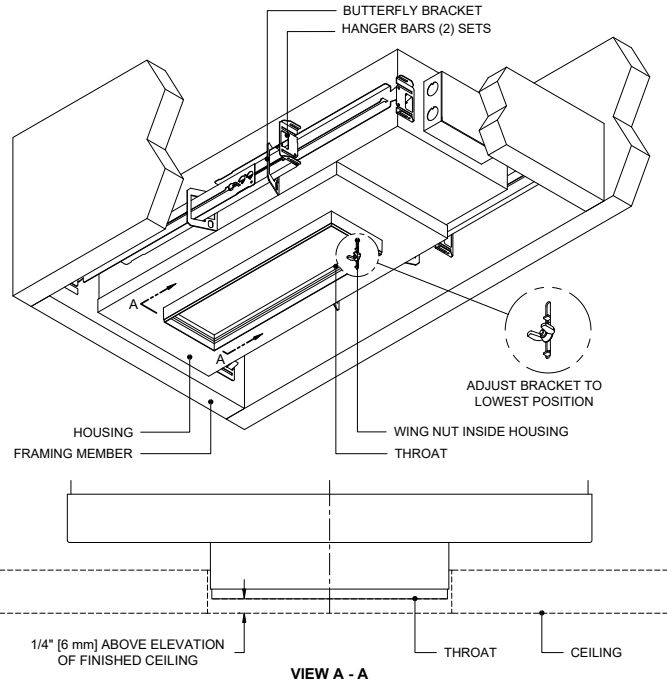

Step C

Cut rectangular cut-out in ceiling. Refer to drawing below for dimensions.

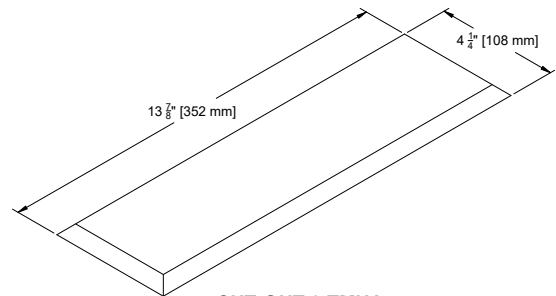

CUT-OUT 3 TMHA

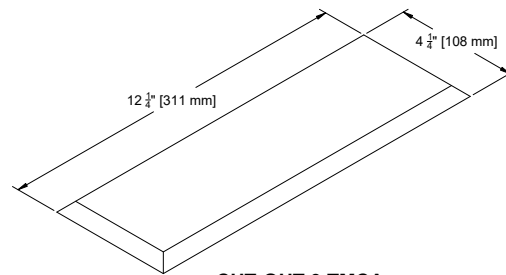

CUT-OUT 3 TMCA

** LED'S SHOULD BE PROTECTED FROM DUST AND DEBRIS DURING INSTALLATION AND MAINTENANCE

[Click here to read full Care and Maintenance](#)

Step D

Install ceiling assuring cut-out aligns with center of housing throat. Lower housing by loosening internal wing nut on butterfly bracket and moving housing down until face of throat meets face of ceiling.

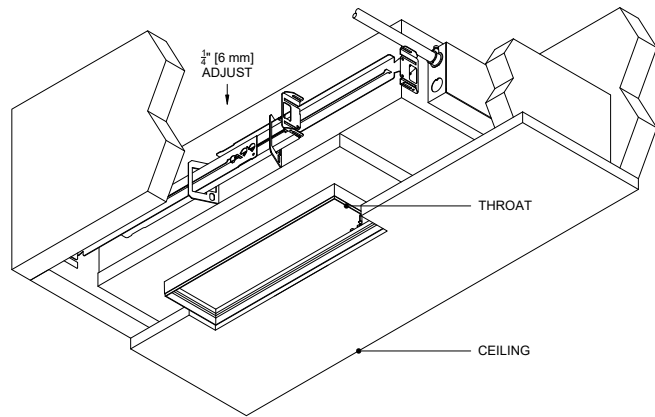

Step F

For flanged trim ensure is properly secured with the springs. If trim is not flush with finished ceiling, remove trim by pulling downward on trim until springs disengage from throat. Loosen wing nuts inside housing and move housing up or down as required, re-tighten wing nuts. Re-install trim.

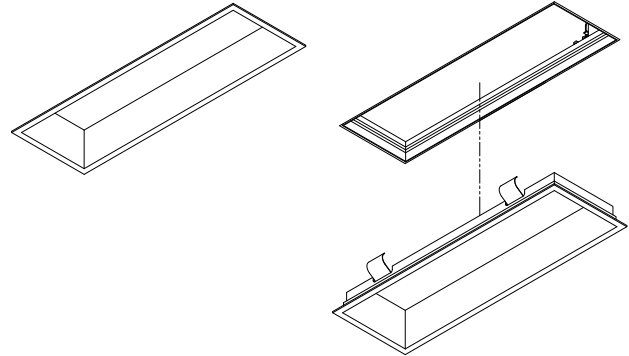

Step E

Push trim into throat until springs catch the top of the throat and flange of the trim is flush against the ceiling. For zero trim push trim into throat until ball plungers catch the retainers.

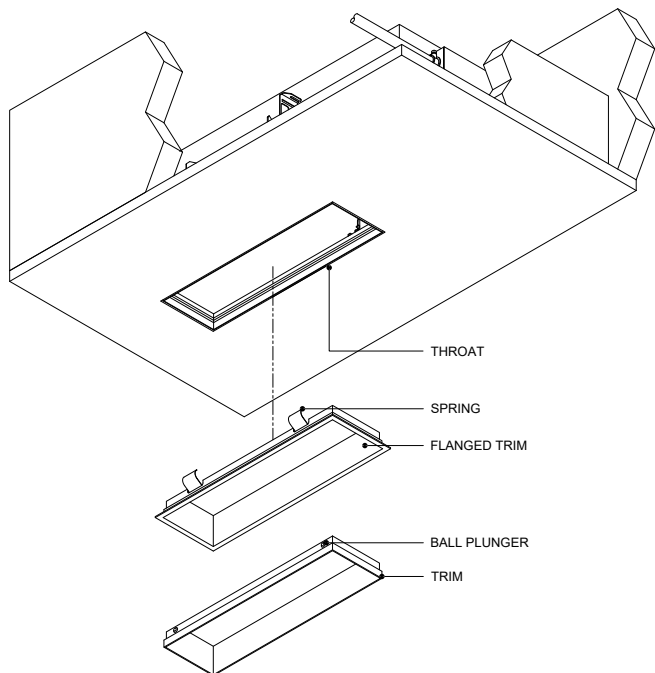

Step G

For flangeless trim, ensure trim is properly secured with the ball plungers. If trim is not flush with finished ceiling, remove trim by pulling downward on trim until ball plungers disengage from throat. Loosen wing nuts inside housing and move housing up or down as required, re-tighten wing nuts. Re-install trim.

