

# Installation Instructions

## Core Square Panel Mount

for CR4D-SA, CR4D-SF, CR4MD-SDH, CRV4D-SA, CR4WW-SF and CR4WW-SA

### Cautions and Warnings

1. This product must be installed in accordance with the applicable installation code by a licensed electrician familiar with the construction and operation of the product and hazards involved.
2. Power must be OFF when connecting the fixture. "hot plugging" devices will damage the LED source.
3. The light engine is low voltage and is factory wired to the driver DO NOT CONNECT LIGHT ENGINE TO MAINS AC POWER.
4. Polarity is important. Black must be connected to black and red connected to red.

### Step B

1. Make electrical connections in junction box.

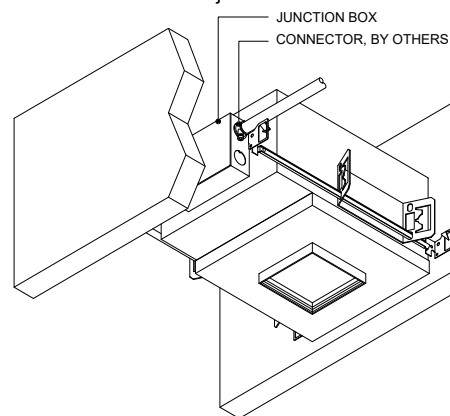

### Step A

1. Mount housing to structure using included hanger bars. Adjust butterfly bracket position using internal wing nut to bottom of slot, so that housing is in highest position with respect to butterfly bracket. In this position there is 1/2" of vertical adjustment to lower housing to meet counterbore wood ceiling. Mount fixture to structure so that the throat is 1/2" above the elevation of finished ceiling.

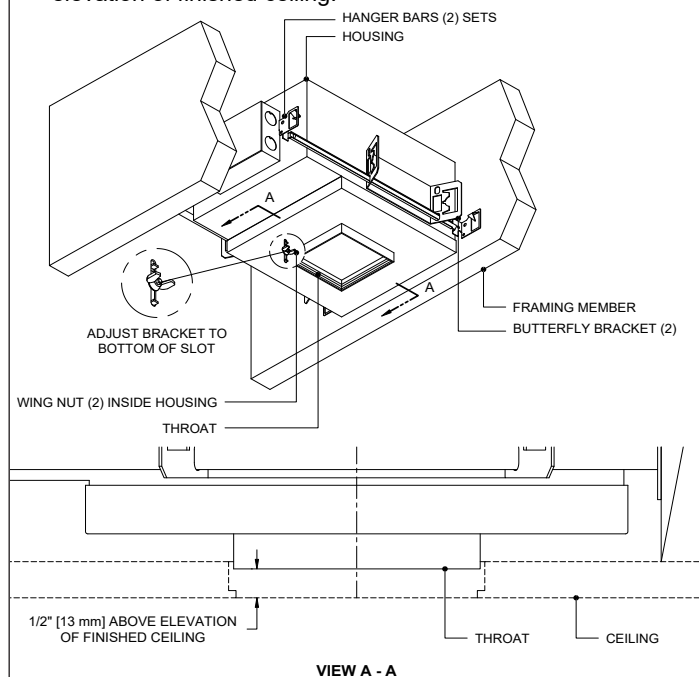

### Step C

1. Cut 4 - 1/16" sq. hole in panel.
2. Counterbore 4 - 5/16" sq. topside on base ceiling panel.

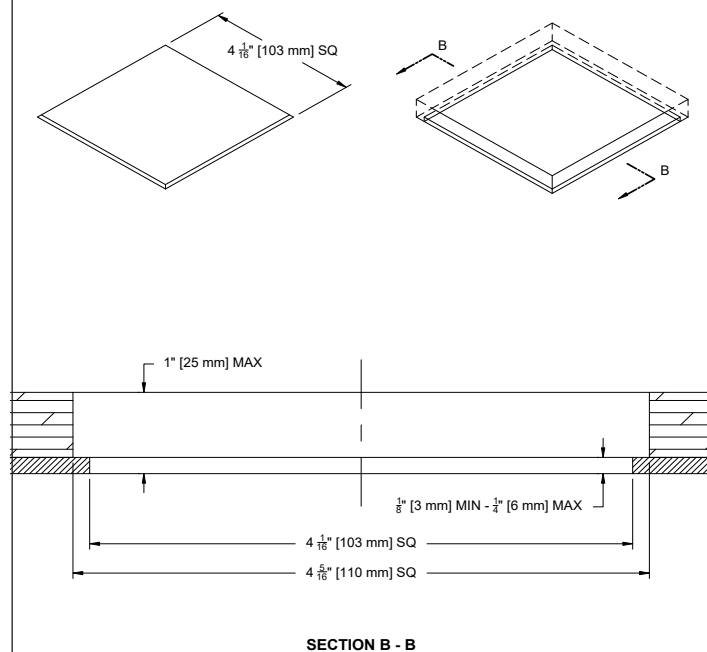

# Installation Instructions Core Square Panel Mount

for CR4D-SA, CR4D-SF, CR4MD-SDH, CRV4D-SA, CR4WW-SF and CR4WW-SA

## Step D

1. Install ceiling ensuring counterbore and cut-out align with housing throat. Lower housing by loosening internal wing nut on butterfly bracket and moving housing down until face of throat meets topside of panel, within counterbore.

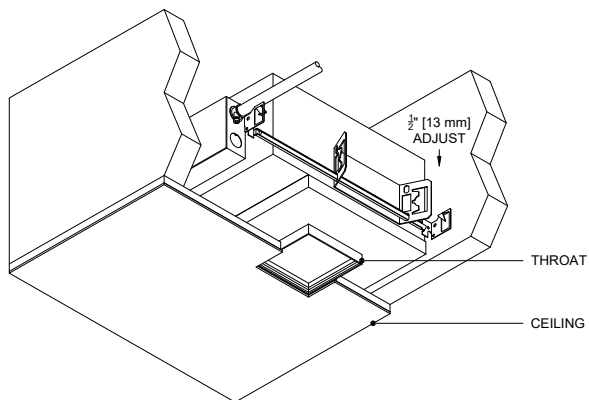

## Step F

1. Ensure trim is properly secured with the ball plungers. If trim is not flush with finished ceiling, remove trim by pulling downward on trim until ball plungers disengage from throat. Loosen wing nuts inside housing and move housing up or down as required, re-tighten wing nuts. Re-install trim.

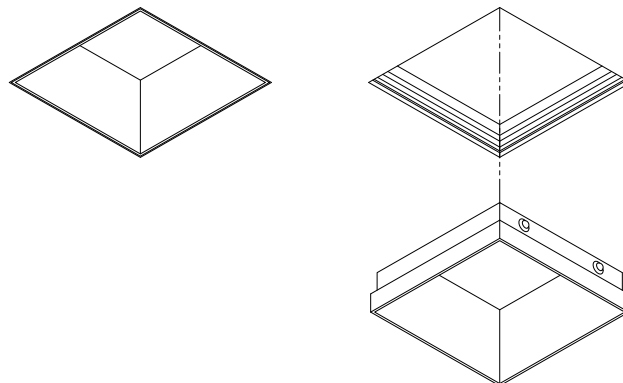

## Step E

1. Push trim into throat until ball plungers catch the retainers (snap). Panel opening cannot be more than 4-1/16" [103 mm] square.

