

Installation Instructions

GrazeFall 2" Linear Baffled Wall Grazer - Flanged Trim & Housing

For GZ2B-RM-FB-F-FH and GZ2B-RM-RB-F-FH

Cautions and Warnings

1. This product must be installed in accordance with the applicable installation code by a licensed electrician familiar with the construction and operation of the product and hazards involved.
2. Power must be OFF when connecting the fixture. "hot plugging" the light engine and driver will damage the LED source.
3. The light engine is low voltage and is factory wired to the driver DO NOT CONNECT LIGHT ENGINE TO MAINS AC POWER.
4. LEDs should be protected from dust and debris during installation and maintenance.
5. Polarity is important. Black must be connected to black and red connected to red.

Step B

Remove LED/driver assembly by pushing the front of baffle with even pressure along length of baffles into housing until pins click and assembly disengages from internal latches.

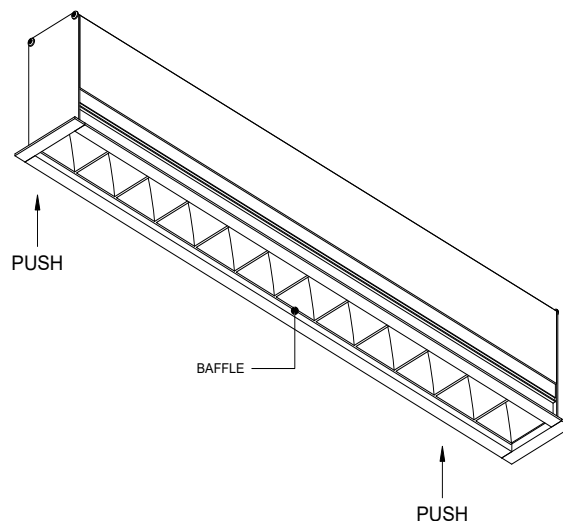

Step A

Install blocking tied to framing at the height above finished floor as indicated on submittal drawing, in locations as indicated on submittal drawings. Make cutout in ceiling at dimensions indicated on submittal drawing.

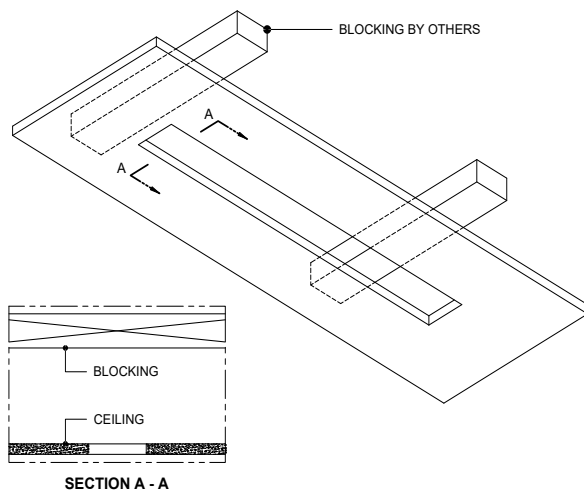

Step C

Remove LED/driver assembly from housing after disengaging from interior latches. Disconnect line voltage connector and set lead aside.

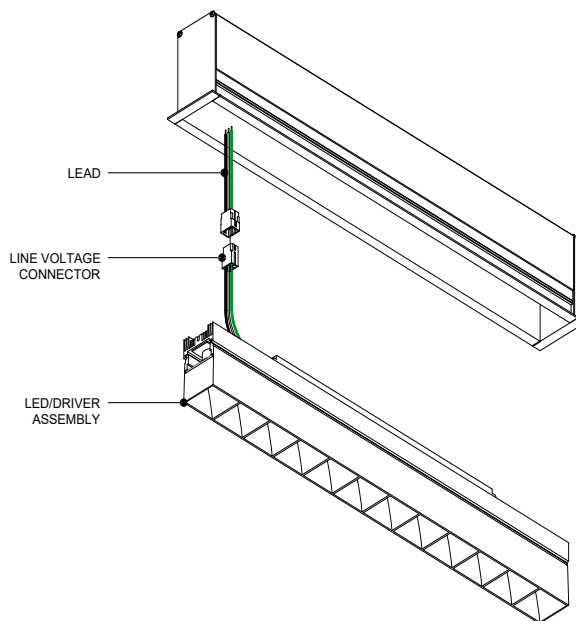

**** LED'S SHOULD BE PROTECTED FROM DUST AND DEBRIS DURING INSTALLATION AND MAINTENANCE**

[Click here to read full Care and Maintenance](#)

Installation Instructions

GrazeFall 2" Linear Baffled Wall Grazer - Flanged Trim & Housing

For GZ2B-RM-FB-F-FH and GZ2B-RM-RB-F-FH

Step D

Prior to installing the housing in ceiling. Connect power to fixture through wiring access plate by removing two screws that fasten the plate to the housing. Connect power to lead with line voltage connector. Replace wiring access plate.

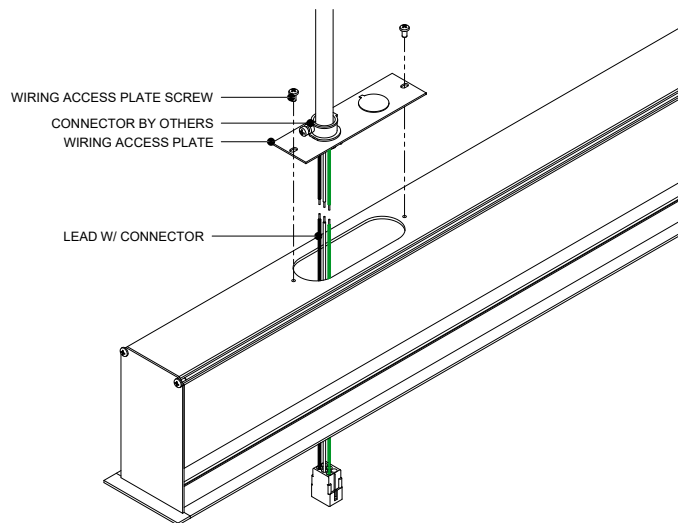

Step F

For run lengths that require multiple sections. Lift housing into place until flush and aligned. Guide pin/joiner into corresponding slot. Mount fixture in ceiling as shown in step C.

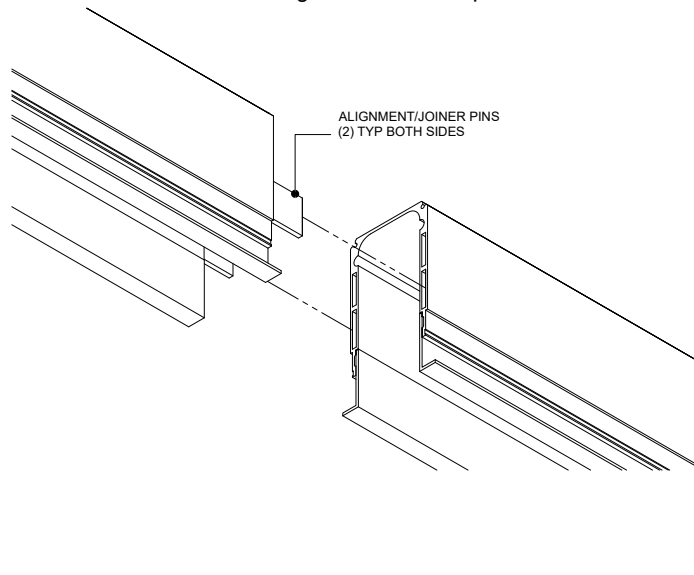

Step E

Mount fixture through housing to blocking above cutout with #8 wood screws or fasteners suitable for blocking material used.

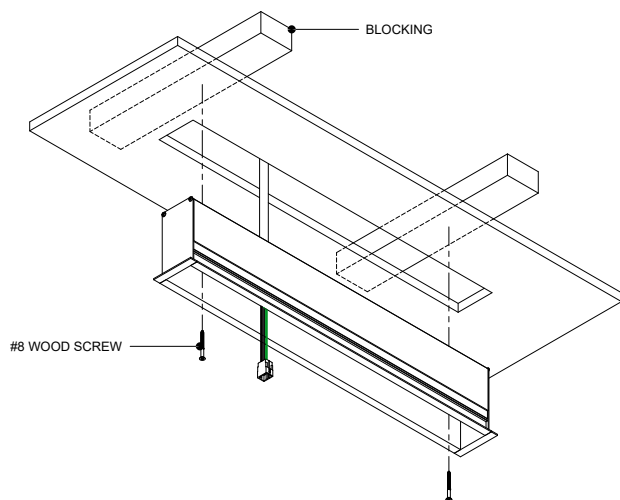

Step G

Reconnect LED/driver assembly to line voltage connector installed. Align LED/driver assembly with opening in housing. Install assembly so that pins align and catch holes in the interior latches.

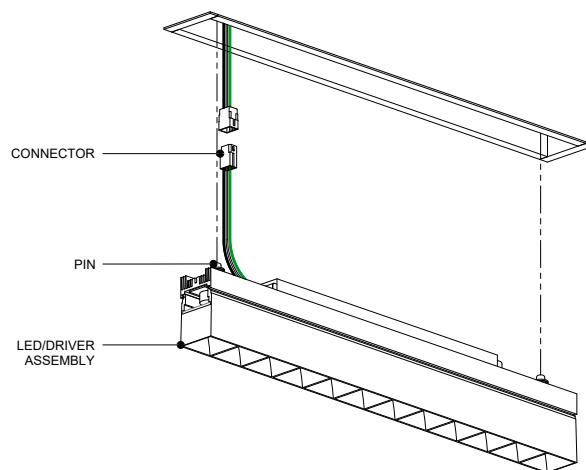

Installation Instructions

GrazeFall 2" Linear Baffled Wall Grazer - Flanged Trim & Housing

For GZ2B-RM-FB-F-FH and GZ2B-RM-RB-F-FH

Step H

Push LED/driver assembly into the housing until it clicks. Then slowly lower assembly into position. Take caution to ensure pins are connected to interior latches. If assembly isn't connected to latch. Repeat pushing assembly into housing until there is a click.

