

Cautions and Warnings

1. This product must be installed in accordance with the applicable installation code by a licensed electrician familiar with the construction and operation of the product and hazards involved.
2. Power must be OFF when connecting the fixture. "hot plugging" the light engine and driver will damage the LED source.
3. The light engine is low voltage and is factory wired to the driver DO NOT CONNECT LIGHT ENGINE TO MAINS AC POWER.
4. LEDs should be protected from dust and debris during during installation and maintenance.
5. Polarity is important. Black must be connected to black and red connected to red.

Step B

Cut $\text{Ø}1/2"$ [13 mm] opening in ceiling to allow for flush mount of fixture. Refer to submittal drawing or cutsheet for location and quantity of feeds.

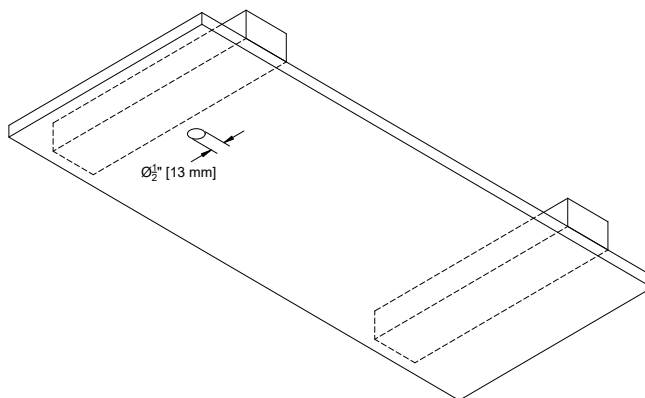

Step A

Install blocking tied to framing at mounting points behind surface fixture is being mounted to at locations as indicated in submittal drawing. Refer to submittal drawing for location and quantity of mounting holes.

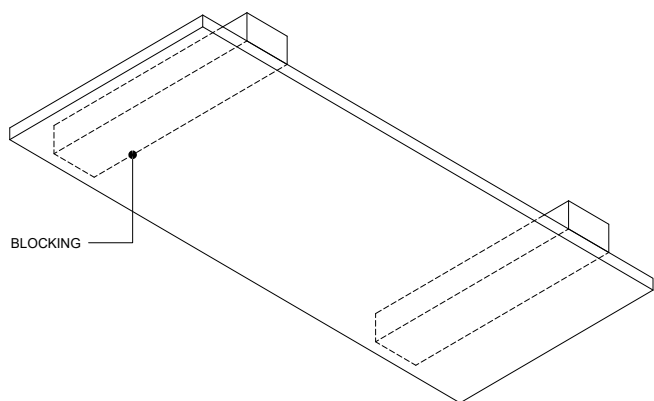

Step C

Gently pry lens from housing. Remove LED assembly from housing by pulling LED assembly until springs retaining assembly in housing are clear of housing. Disconnect connector, set LED assembly and lens aside.

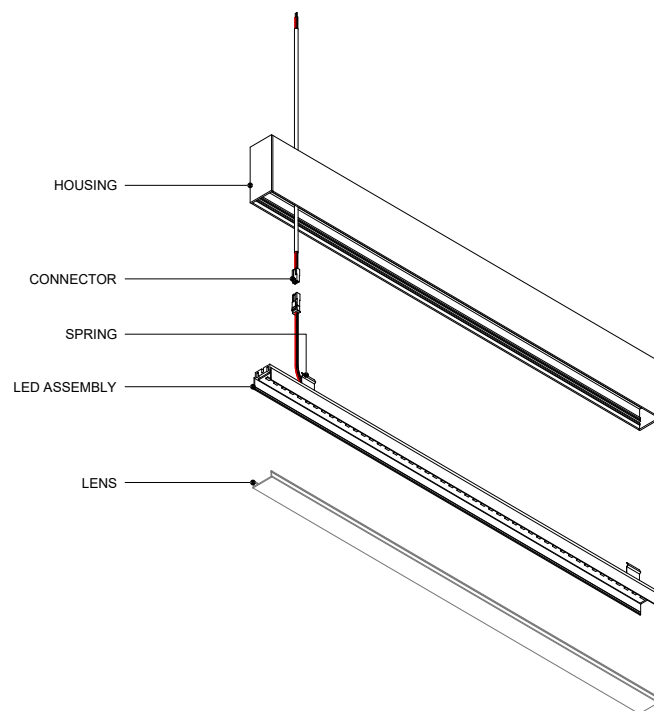

** LED'S SHOULD BE PROTECTED FROM DUST AND DEBRIS DURING INSTALLATION AND MAINTENANCE

[Click here to read full Care and Maintenance](#)

Step D

Prior to installing the housing onto surface. Connect leads from the housing to their respective leads from the remote driver. ENSURE POSTIVE, RED (+) IS CONNECTED TO POSTIVE, RED (+) AND NEGATIVE, BLACK (-) IS CONNECTED TO NEGATIVE, BLACK (-).

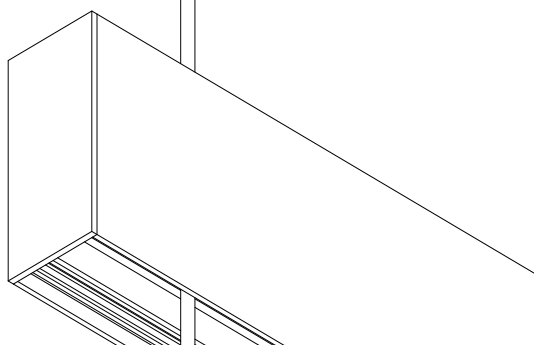
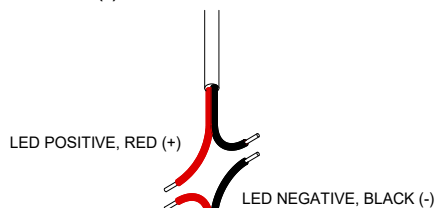

Step F

For run lengths that require multiple sections. Pin/joiners may be moved by loosening set screw with 2mm hex wrench and sliding within slot inside of the housing. Lift housing into place until flush and aligned. Guide pin/joiner into corresponding slot. Tighten set screws on pin/joiners to secure housings to one another. Install to surface as shown in step E.

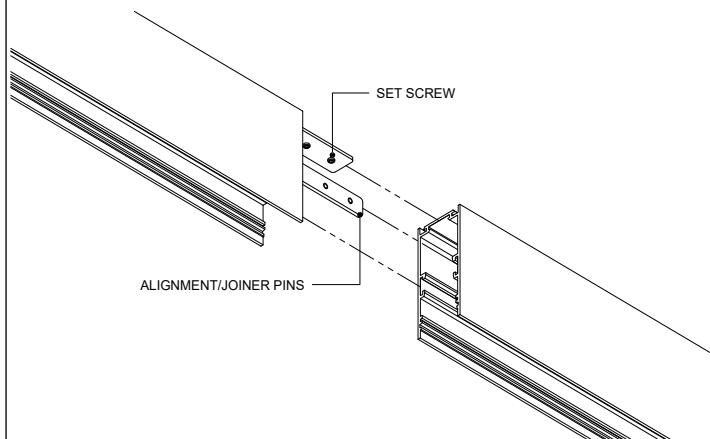

Step E

Mount housing to surface with wood screws or fasteners suitable for blocking material used (by others) through housing into blocking.

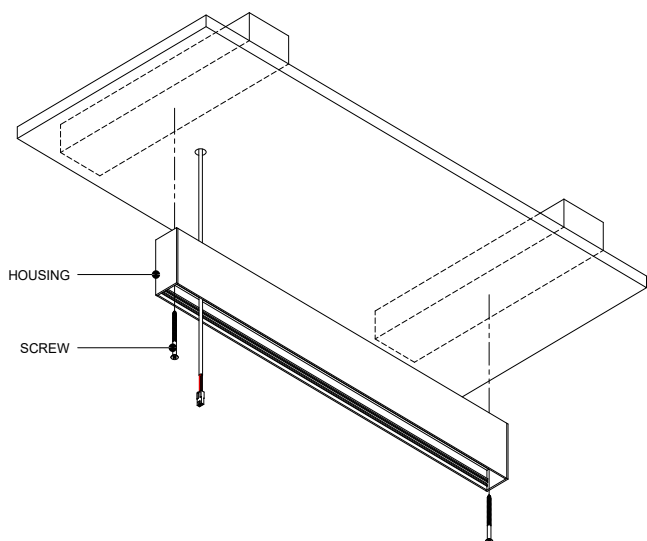

Step G

Prior to reinstalling LED assembly into housing, make electrical connection between housing and LED assembly, connect included safety cables then secure assembly to housing by pushing assembly into housing until springs on LED assembly securely engage the housing. Reinstall lens by pushing lens into housing until it is securely clipped in. Turn on power to check electrical connection.

